

NPN Silicon Switching Transistors

BSS 79
BSS 81

- High DC current gain
- Low collector-emitter saturation voltage
- Complementary types: BSS 80, BSS 82 (PNP)

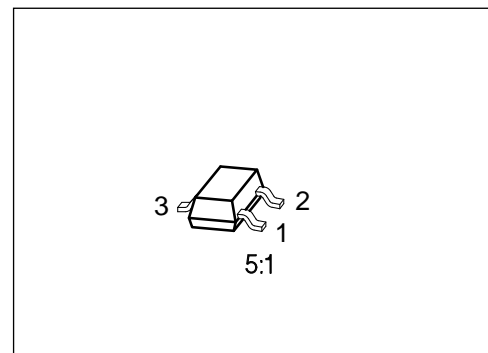

Type	Marking	Ordering Code (tape and reel)	Pin Configuration			Package ¹⁾
			1	2	3	
BSS 79 B	CEs	Q62702-S503	B	E	C	SOT-23
BSS 79 C	CFs	Q62702-S501				
BSS 81 B	CDs	Q62702-S555				
BSS 81 C	CGs	Q62702-S605				

Maximum Ratings

Parameter	Symbol	Values		Unit
		BSS 79	BSS 81	
Collector-emitter voltage	V_{CE0}	40	35	V
Collector-base voltage	V_{CB0}	75		
Emitter-base voltage	V_{EB0}	6		
Collector current	I_C	800		mA
Peak collector current	I_{CM}	1		A
Base current	I_B	100		mA
Peak base current	I_{BM}	200		
Total power dissipation, $T_s = 77\text{ °C}$	P_{tot}	330		mW
Junction temperature	T_j	150		°C
Storage temperature range	T_{stg}	- 65 ... + 150		

Thermal Resistance

Junction - ambient ²⁾	$R_{th\ JA}$	≤ 290	K/W
Junction - soldering point	$R_{th\ JS}$	≤ 220	

¹⁾ For detailed information see chapter Package Outlines.

²⁾ Package mounted on epoxy pcb 40 mm × 40 mm × 1.5 mm/6 cm² Cu.

Electrical Characteristics

at $T_A = 25\text{ °C}$, unless otherwise specified.

Parameter	Symbol	Values			Unit
		min.	typ.	max.	

DC characteristics

Collector-emitter breakdown voltage $I_C = 10\text{ mA}$	$V_{(BR)CE0}$	40 35	— —	— —	V
Collector-base breakdown voltage $I_C = 10\text{ }\mu\text{A}$	$V_{(BR)CB0}$	75	—	—	
Emitter-base breakdown voltage $I_E = 10\text{ }\mu\text{A}$	$V_{(BR)EB0}$	6	—	—	
Collector-base cutoff current $V_{CB} = 60\text{ V}$ $V_{CB} = 60\text{ V}, T_A = 150\text{ °C}$	I_{CB0}	— —	— —	10 10	nA μA
Emitter-base cutoff current $V_{EB} = 3\text{ V}$	I_{EB0}	—	—	10	nA
DC current gain $I_C = 100\text{ }\mu\text{A}, V_{CE} = 10\text{ V}$	h_{FE}	BSS 79 B/81 B	20	—	—
		BSS 79 C/81 C	35	—	—
$I_C = 1\text{ mA}, V_{CE} = 10\text{ V}$		BSS 79 B/81 B	25	—	—
		BSS 79 C/81 C	50	—	—
$I_C = 10\text{ mA}, V_{CE} = 10\text{ V}^{1)}$		BSS 79 B/81 B	35	—	—
		BSS 79 C/81 C	75	—	—
$I_C = 150\text{ mA}, V_{CE} = 10\text{ V}^{1)}$		BSS 79 B/81 B	40	—	120
	BSS 79 C/81 C	100	—	300	
$I_C = 500\text{ mA}, V_{CE} = 10\text{ V}^{1)}$	BSS 79 B/81 B	25	—	—	
	BSS 79 C/81 C	40	—	—	
Collector-emitter saturation voltage ¹⁾ $I_C = 150\text{ mA}, I_B = 15\text{ mA}$ $I_C = 500\text{ mA}, I_B = 50\text{ mA}$	V_{CEsat}	— —	— —	0.3 1.3	V
Base-emitter saturation voltage ¹⁾ $I_C = 150\text{ mA}, I_B = 15\text{ mA}$ $I_C = 500\text{ mA}, I_B = 50\text{ mA}$	V_{BEsat}	— —	— —	1.2 2.0	

¹⁾ Pulse test conditions: $t \leq 300\text{ }\mu\text{s}, D = 2\%$.

Electrical Characteristics

at $T_A = 25\text{ }^\circ\text{C}$, unless otherwise specified.

Parameter	Symbol	Values			Unit
		min.	typ.	max.	

AC characteristics

Transition frequency $I_C = 20\text{ mA}$, $V_{CE} = 20\text{ V}$, $f = 100\text{ MHz}$	f_T	—	250	—	MHz
Open-circuit output capacitance $V_{CB} = 10\text{ V}$, $f = 1\text{ MHz}$	C_{obo}	—	6	—	pF
$V_{CC} = 30\text{ V}$, $I_C = 150\text{ mA}$, $I_{B1} = I_{B2} = 15\text{ mA}$, $V_{BE} = 0.5\text{ V}$					
Delay time	t_d	—	—	10	ns
Rise time	t_r	—	—	25	ns
Storage time	t_{stg}	—	—	250	ns
Fall time	t_f	—	—	60	ns

Test circuits

Delay and rise time

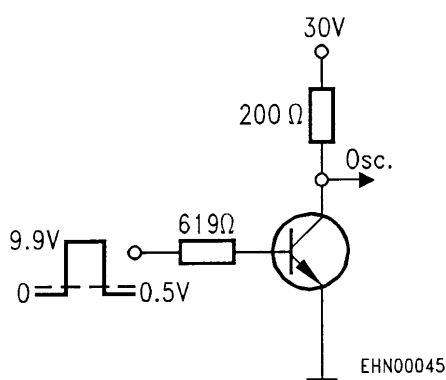

Storage and fall time

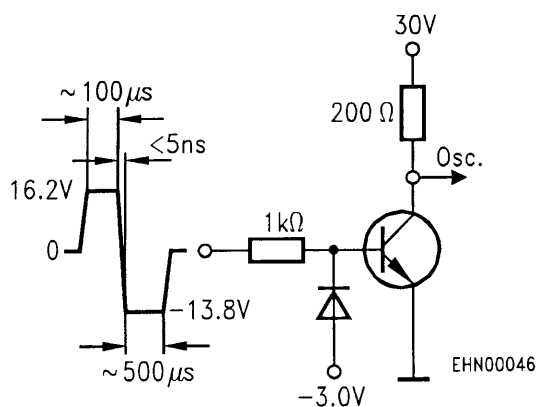

Oscillograph: $R > 100\text{ k}\Omega$
 $C < 12\text{ pF}$
 $t_r < 5\text{ ns}$

Total power dissipation $P_{tot} = f(T_A^*; T_S)$

* Package mounted on epoxy

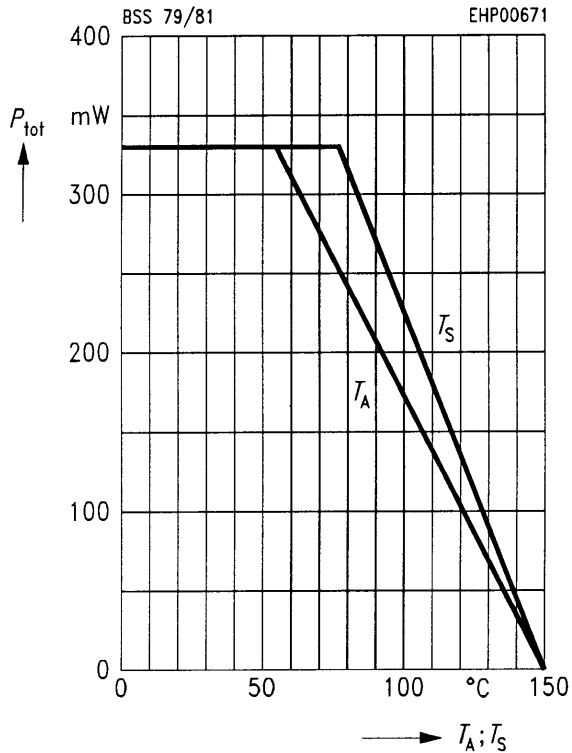

Collector-base capacitance $C_{cb} = f(V_{CB})$

$f = 1 \text{ MHz}$

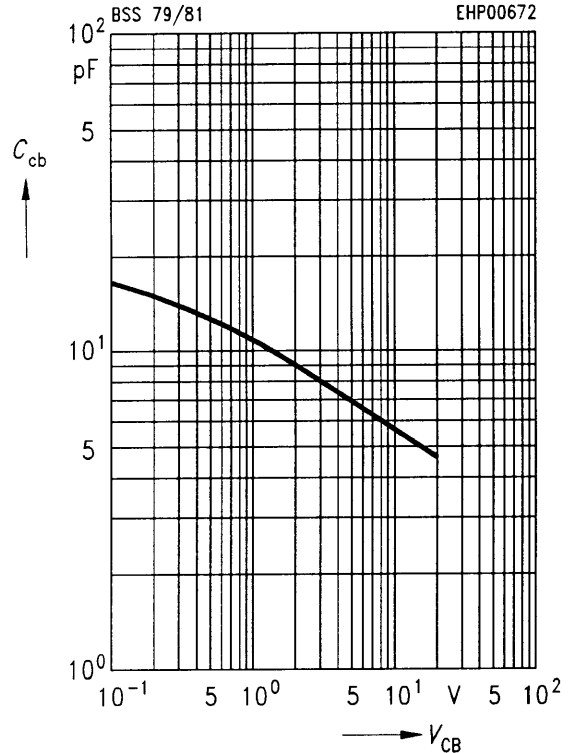

Permissible pulse load $P_{tot \text{ max}} / P_{tot \text{ DC}} = f(t_p)$

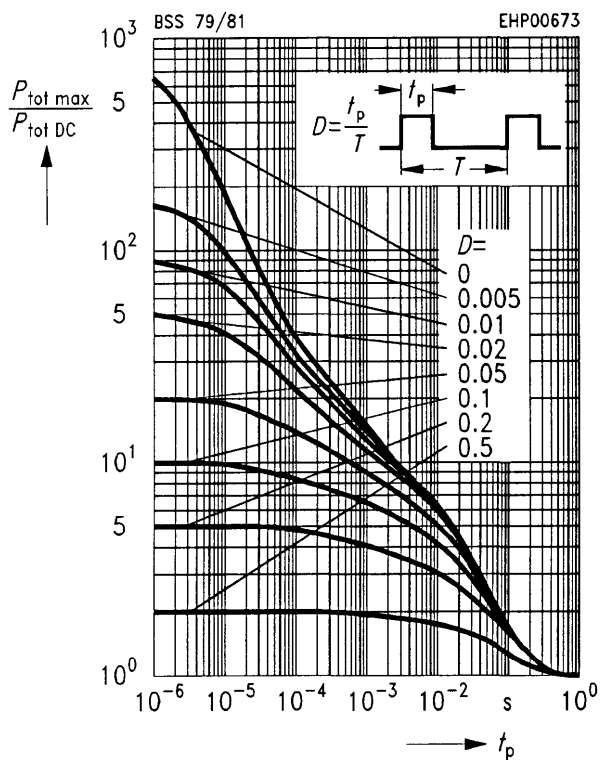

Transition frequency $f_T = f(I_C)$

$V_{CE} = 20 \text{ V}$

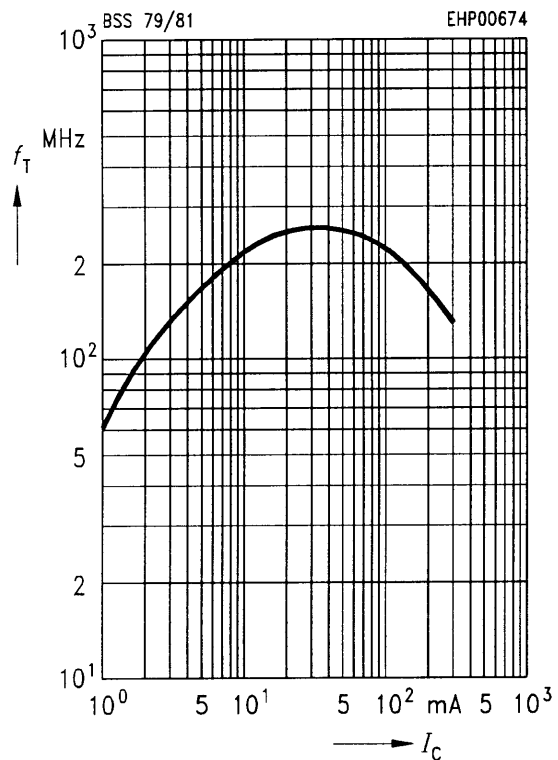

Saturation voltage $I_C = f(V_{BE\ sat})$
 $h_{FE} = 10$ $I_C = f(V_{CE\ sat})$

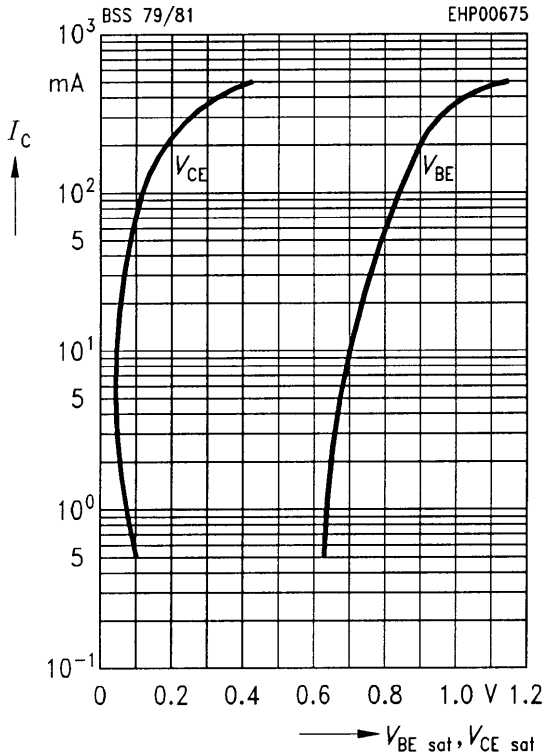

DC current gain $h_{FE} = f(I_C)$
 $V_{CE} = 10\ V$

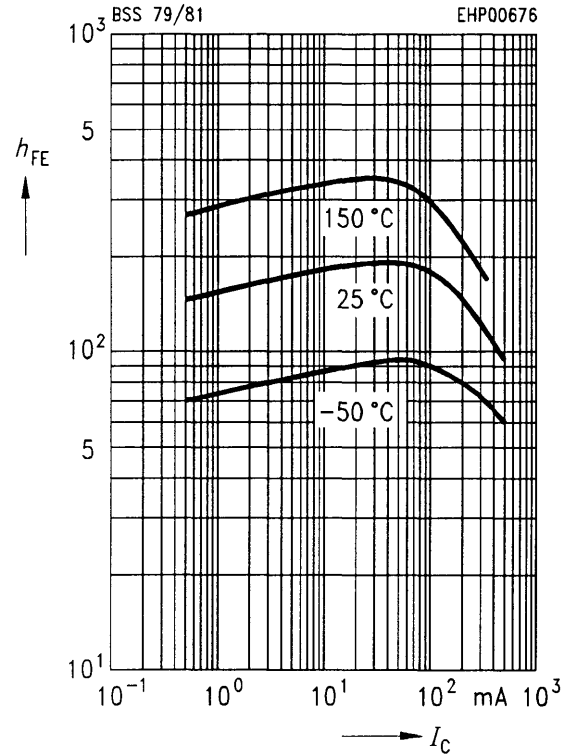

Delay time $t_d = f(I_C)$
Rise time $t_r = f(I_C)$

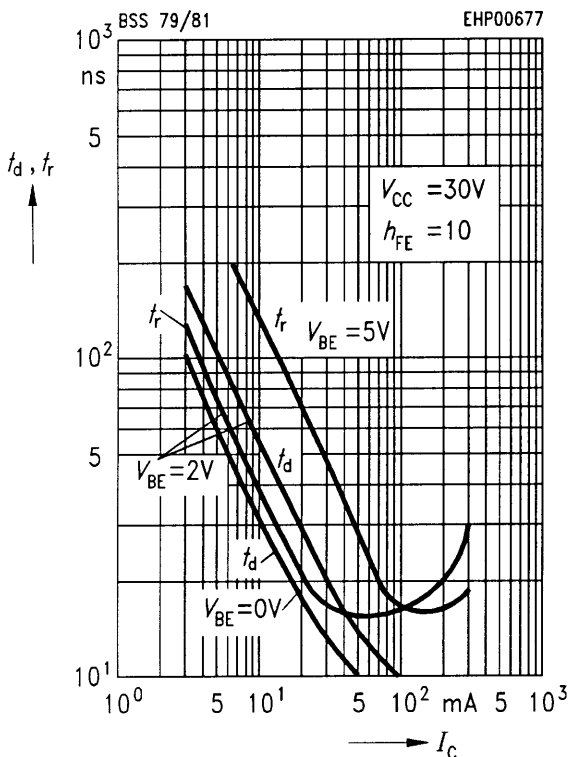

Storage time $t_{stg} = f(I_C)$
Fall time $t_f = f(I_C)$

